

## APPLICATIONS

Compact folding machine available with 2 or 3 lengthways folds and a maximum number of 4 lanes. Mekos is normally combined with the Clino self-feed-in the counter folding machine.

## FEATURES

The mechanical folding technique with belt reversal ensures folding consistency and precision regardless of item size and fabric type.

Automatic programmes are available with selection based on item length. The different workstations can be synchronised in any combination.

One single motor drives all machines regardless of the number of lanes. No pneumatic adjustment is required. Air consumption is very low.

## CONFIGURATIONS

**Working widths:** 1330 – 1720 – 2220 – 2620 – 3020 – 3320 – 3520 – 4020 mm

**Folding types:**

- In half
- Into thirds
- Constant format
- Bypass

**Folding speed:** standard at 36 m/min





*Standard configurations:*

MACHINE WIDTH	No. LANES	CONFIGURATION	No FOLDS	MAX. WIDTH ITEMS TO BE FOLDED
1330	1	1x1200	2-3	1140
1720	1	1x1640	2-3	1580
2220	2	2x1100	2-3	1040
2620	2	2x1300	2-3	1240
3020	3	3x1000	2	940
3320	3	3x1100	2	1040
		3x1100	3	1060 (with 2 folds length 1750)
		1x700 + 2x1300	2-3	1240/640
	4	4x825	2	765
	4	1x1200 + 3x700	2-3	1160/670 (with 2 folds length 1750)
3520	3	3x1166	2-3	1100
		1x1300 + 2x1100	2	1260/1060 (with 2 folds length 1750)
		1x1300 + 2x1100	3	1260/1060 (with 2 folds length 2400)
	4	4x875	2	815
		1x1400 + 3x700	2	1340/640
4020	4	4x1000	2-3	940

## TECHNICAL DETAILS

2950

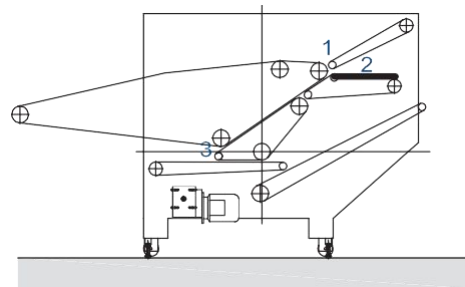
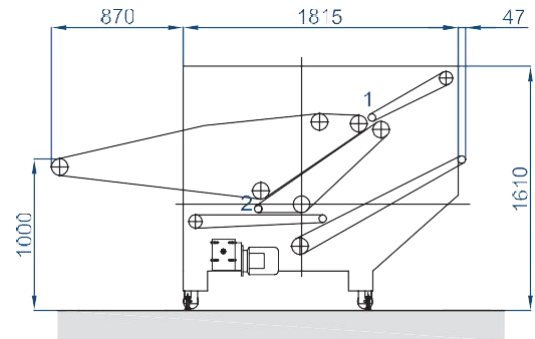
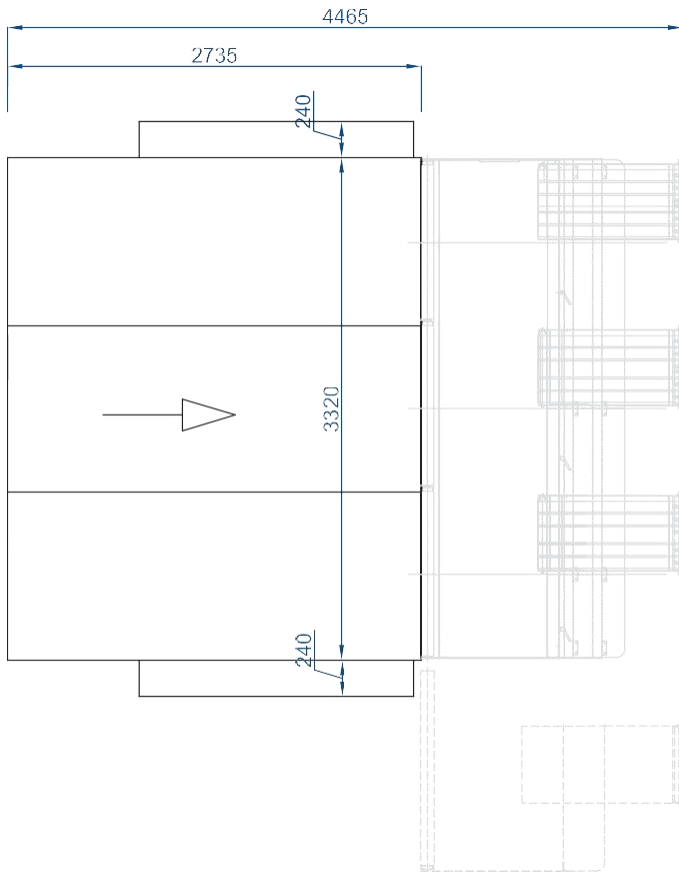

### TECHNICAL DETAILS

Installed electrical power	1.5 kW
Electric current voltage	3x400V+N+T - 50Hz
Min. compressed air pressure	5 bar
Average compressed air consumption	50 NL/min
Weight	1800 kg